

N/F
SCHMIDT
AM 34 PR 42A
DB 34717 PG 139

N/F
POTHIER
AM 34 PR 43
DB 17477 PG 272

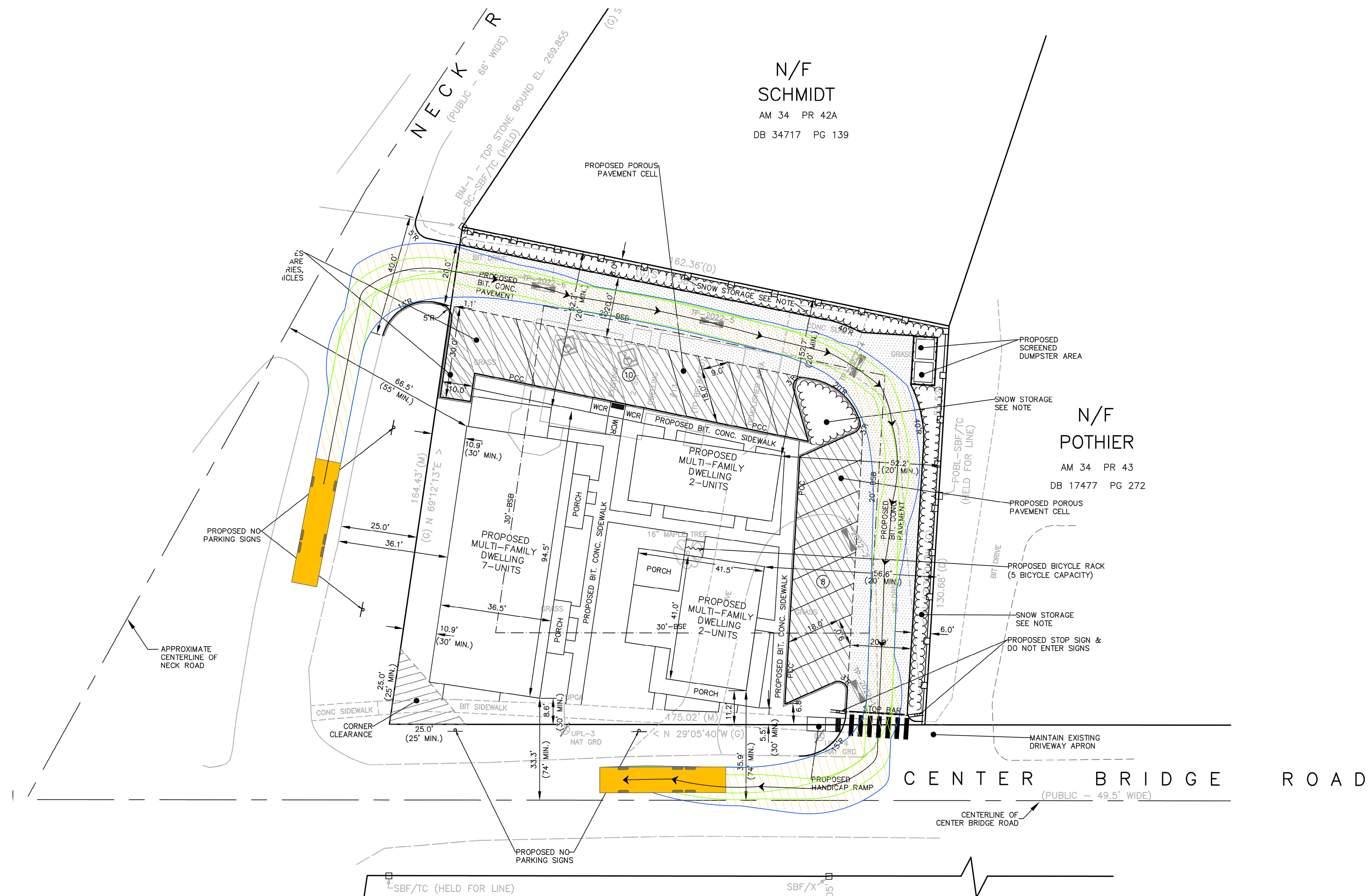

NOTES

1. THIS PLAN INTENDED FOR DISCUSSION PURPOSES ONLY; IT IS NOT FOR CONSTRUCTION.
2. FINAL DESIGN IS SUBJECT TO FIELD SURVEY BY OTHERS.
3. PROPERTY LINES AND ACCESS LINE LOCATIONS ARE APPROXIMATE ONLY AND ARE SUBJECT TO DEED AND TITLE RECORDS.
4. BASE PLAN SOURCE: HANCOCK ASSOCIATES.

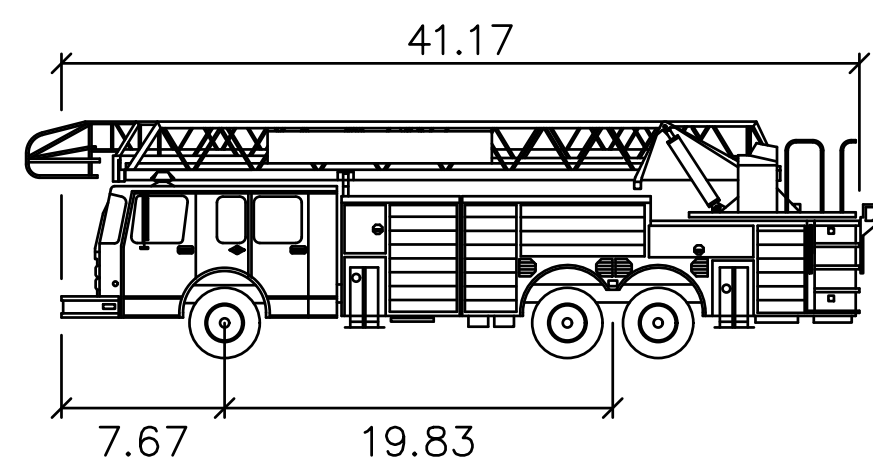

Lancaster KME 109' RMA

	feet
Width	: 8.33
Track	: 8.33
Lock to Lock Time	: 6.0
Steering Angle	: 40.6

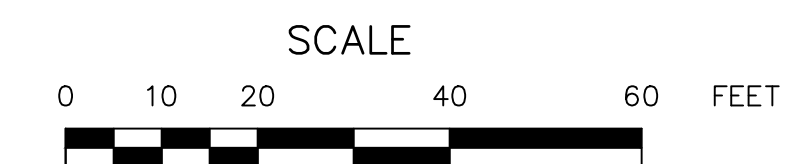

AutoTurn Analysis - Fire Truck

AutoTurn Analysis
13 NECK ROAD
LANCASTER, MASSACHUSETTS
PREPARED FOR:
NECK FARM, LLC
66 WEST STREET, SUITE 1F
LEOMINSTER, MA 01453

MDM TRANSPORTATION CONSULTANTS, INC.
PLANNERS & ENGINEERS

28 Lord Road, Suite 280
Marlborough, MA 01752
Tel: (508) 303-0370
Fax: (508) 303-0371

DATE: April 2024	File: 1341 Autoturn (4-1-24).dwg
PROJECT No. 1341	Scale: As Noted
	Sheet 1 of 1

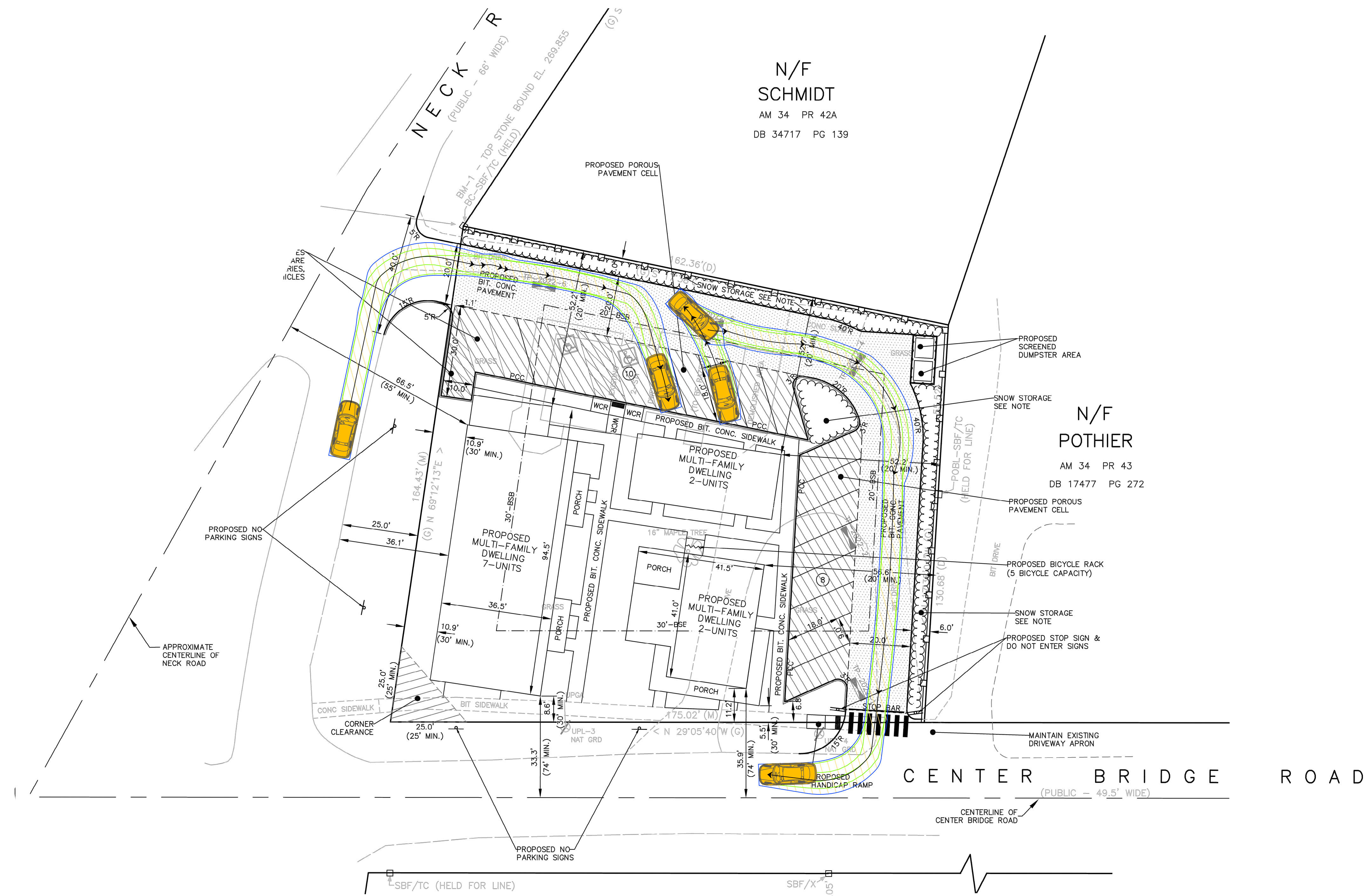
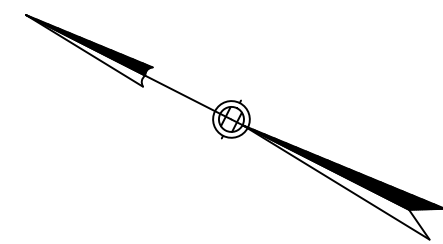

N/F
SCHMIDT
AM 34 PR 42A
DB 34717 PG 139

N/F
POTHIER
AM 34 PR 43
DB 17477 PG 272

CENTER BRIDGE ROAD
(PUBLIC - 49.5' WIDE)

NOTES

1. THIS PLAN INTENDED FOR DISCUSSION PURPOSES ONLY; IT IS NOT FOR CONSTRUCTION.
2. FINAL DESIGN IS SUBJECT TO FIELD SURVEY BY OTHERS.
3. PROPERTY LINES AND ACCESS LINE LOCATIONS ARE APPROXIMATE ONLY AND ARE SUBJECT TO DEED AND TITLE RECORDS.
4. BASE PLAN SOURCE: HANCOCK ASSOCIATES.

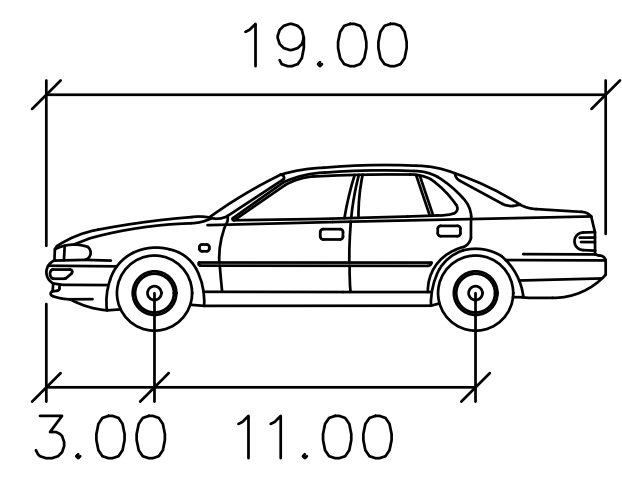

Passenger Vehicle

Width : 7.0 Ft.
Track : 6.0 Ft.
Lock to Lock Time : 6.0 Sec.
Steering Angle : 31.6 Deg.



AutoTurn Analysis - Passenger Car

AutoTurn Analysis
13 NECK ROAD
LANCASTER, MASSACHUSETTS
PREPARED FOR:
NECK FARM, LLC
66 WEST STREET, SUITE 1F
LEOMINSTER, MA 01453

MDM TRANSPORTATION CONSULTANTS, INC.
PLANNERS & ENGINEERS

28 Lord Road, Suite 280
Marlborough, MA 01752
Tel: (508) 303-0370
Fax: (508) 303-0371

DATE: April 2024	File: 1341 Autoturn (4-1-24).dwg
PROJECT No. 1341	Scale: As Noted
	Sheet 1 of 1

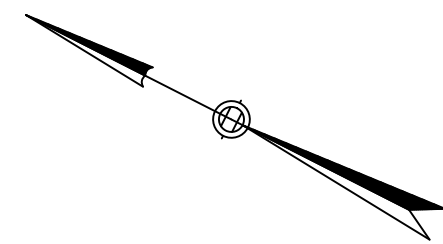

N/F
SCHMIDT
AM 34 PR 42A
DB 34717 PG 139

N/F
POTHIER
AM 34 PR 43
DB 17477 PG 272

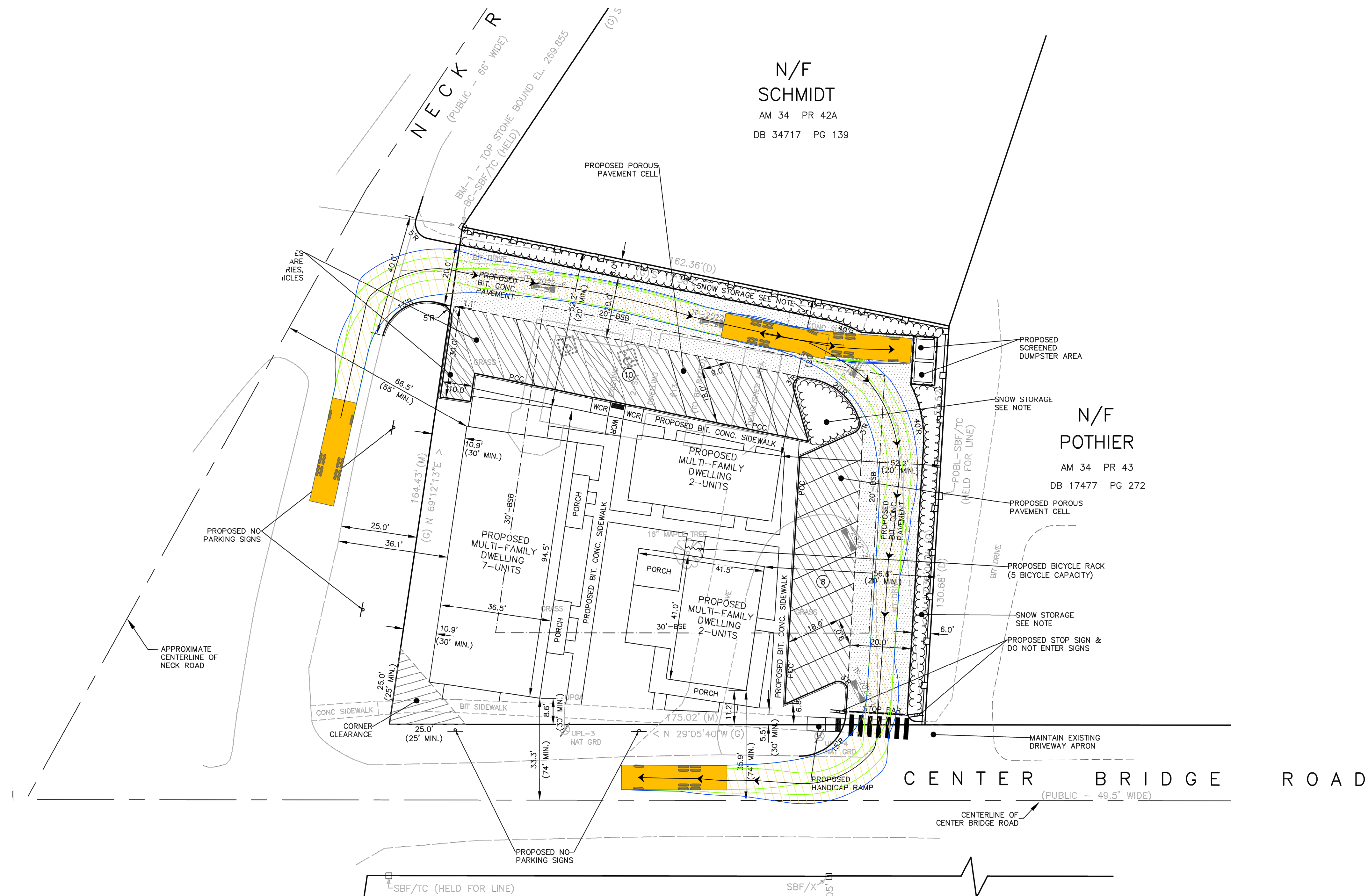

NOTES

1. THIS PLAN INTENDED FOR DISCUSSION PURPOSES ONLY; IT IS NOT FOR CONSTRUCTION.
2. FINAL DESIGN IS SUBJECT TO FIELD SURVEY BY OTHERS.
3. PROPERTY LINES AND ACCESS LINE LOCATIONS ARE APPROXIMATE ONLY AND ARE SUBJECT TO DEED AND TITLE RECORDS.
4. BASE PLAN SOURCE: HANCOCK ASSOCIATES.

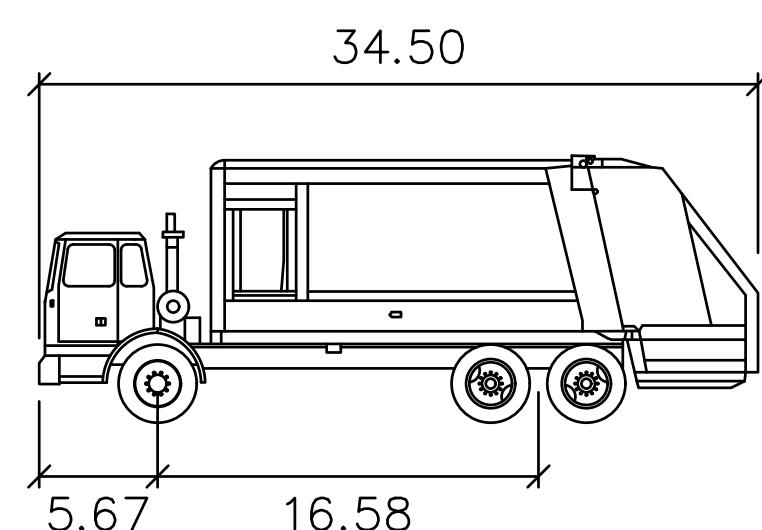

Garbage Truck

Width : 8.0 Ft.
Track : 8.2 Ft.
Lock to Lock Time : 6.0 Sec
Steering Angle : 33.9 Deg

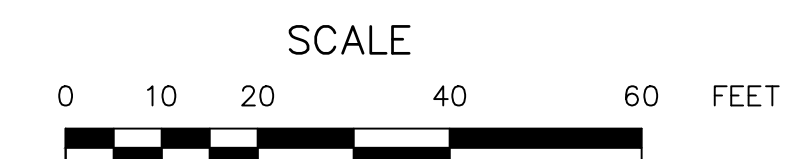

AutoTurn Analysis - Garbage Truck

AutoTurn Analysis
13 NECK ROAD
LANCASTER, MASSACHUSETTS
PREPARED FOR:
NECK FARM, LLC
66 WEST STREET, SUITE 1F
LEOMINSTER, MA 01453

MDM TRANSPORTATION CONSULTANTS, INC.
PLANNERS & ENGINEERS

28 Lord Road, Suite 280
Marlborough, MA 01752
Tel: (508) 303-0370
Fax: (508) 303-0371

DATE: April 2024	File: 1341 Autoturn (4-1-24).dwg
PROJECT No. 1341	Scale: As Noted
	Sheet 1 of 1

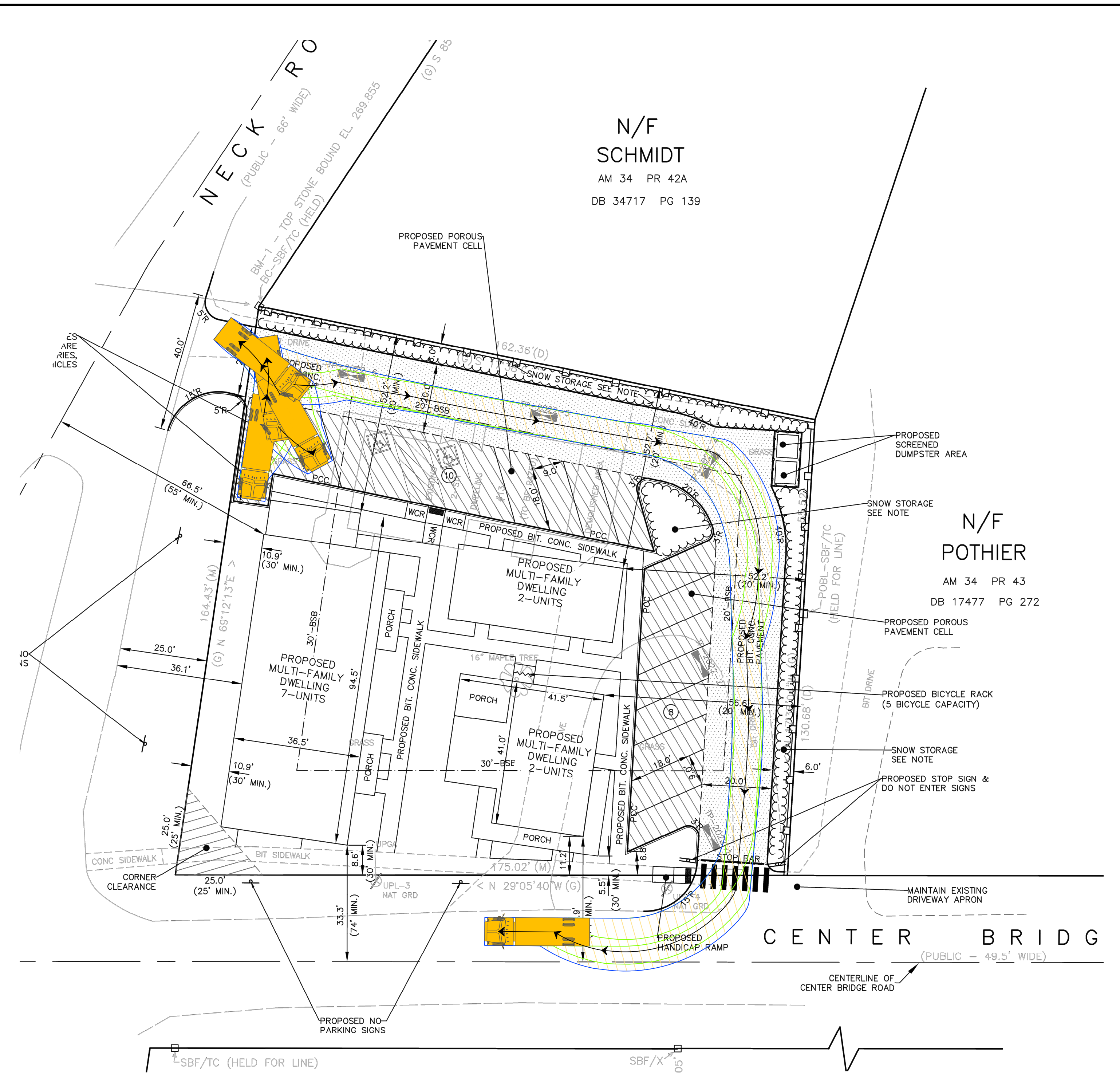
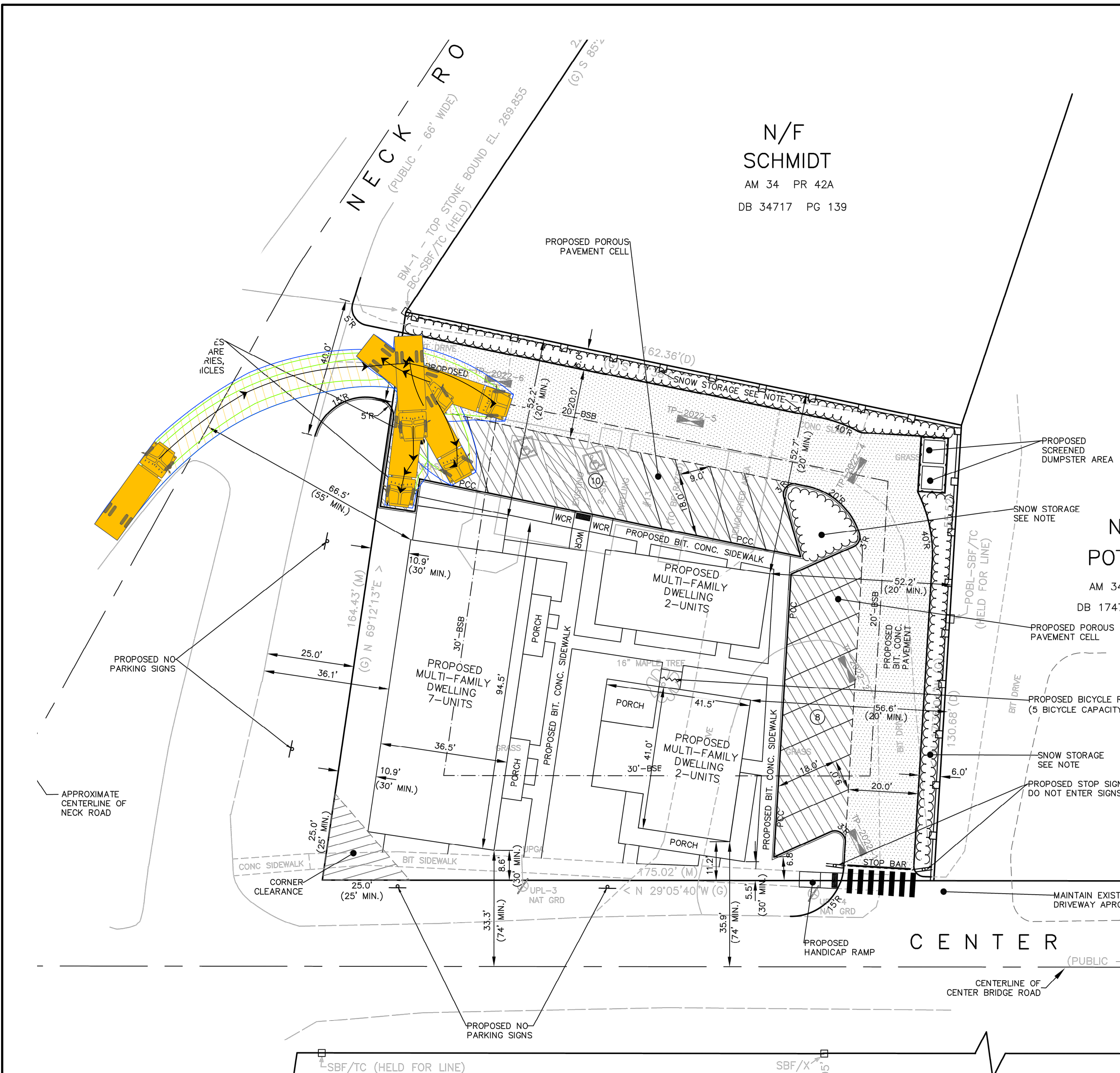

NOTES

1. THIS PLAN INTENDED FOR DISCUSSION PURPOSES ONLY; IT IS NOT FOR CONSTRUCTION.
2. FINAL DESIGN IS SUBJECT TO FIELD SURVEY BY OTHERS.
3. PROPERTY LINES AND ACCESS LINE LOCATIONS ARE APPROXIMATE ONLY AND ARE SUBJECT TO DEED AND TITLE RECORDS.
4. BASE PLAN SOURCE: HANCOCK ASSOCIATES.

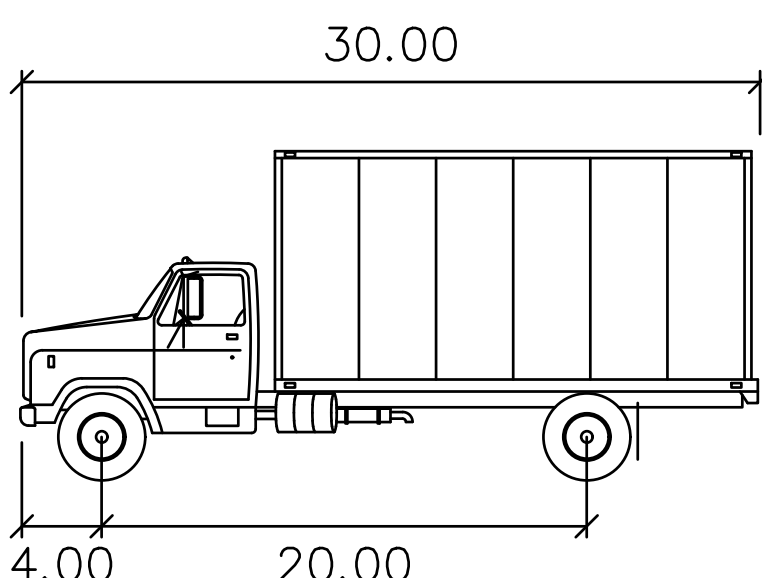

SU-30

Width : 8.0 Ft.
 Track : 8.0 Ft.
 Lock to Lock Time : 6.0 Sec.
 Steering Angle : 31.8 Deg.

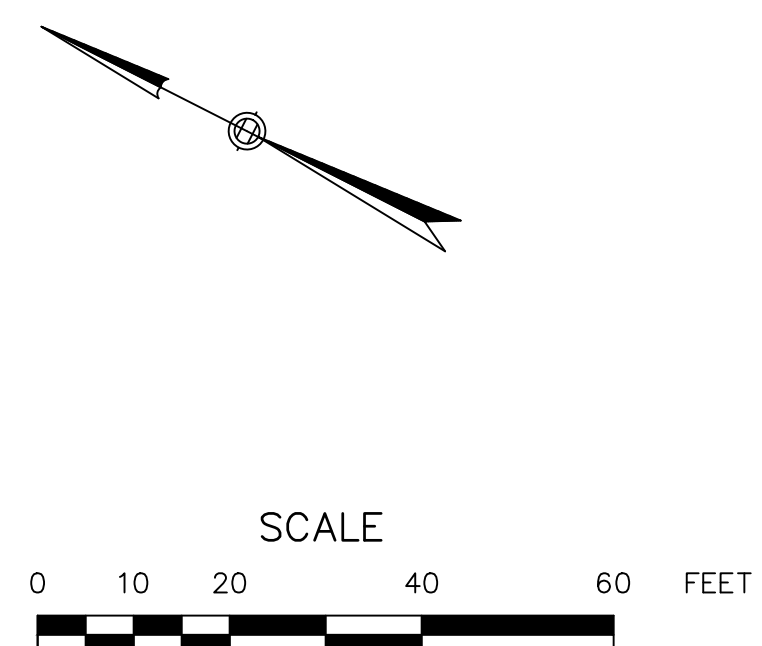

AutoTurn Analysis - SU-30

AutoTurn Analysis
 13 NECK ROAD
 LANCASTER, MASSACHUSETTS
 PREPARED FOR:
 NECK FARM, LLC
 66 WEST STREET, SUITE 1F
 LEOMINSTER, MA 01453

MDM TRANSPORTATION CONSULTANTS, INC.
 PLANNERS & ENGINEERS

28 Lord Road, Suite 280
 Marlborough, MA 01752
 Tel: (508) 303-0370
 Fax: (508) 303-0371

DATE: March 2024	File: 1341 Autoturn.dwg
PROJECT No. 1341	Scale: As Noted
Sheet 1 of 1	